



IsoFlex Technologies Pty Ltd.

Unit 5, 7 Waterway Drive, Gold Coast Marine Precinct, Coomera, Queensland, Australia. 4209
 Ph: 1300 366 393 Ph: 07 555 60 924 F: 07 555 60 984 Int prefix: 617
 Email: info@isoflex.com.au
 Home Page: www.isoflex.com.au

IsoFlex Mount Data Sheet

Loadings:

1. Axial - Vertical Down (A-direction)

Mount Model: M80-20B

'M80' = model number
 '20' = thread size
 'B' = bolt type

Resilient Element Colour	Shore Durometer Hardness A-scale SDH-A
Yellow	50
Red	60
Black	70
Royal Blue	75

Base: Black - 75 SDH-D

All metal components silver zinc plated

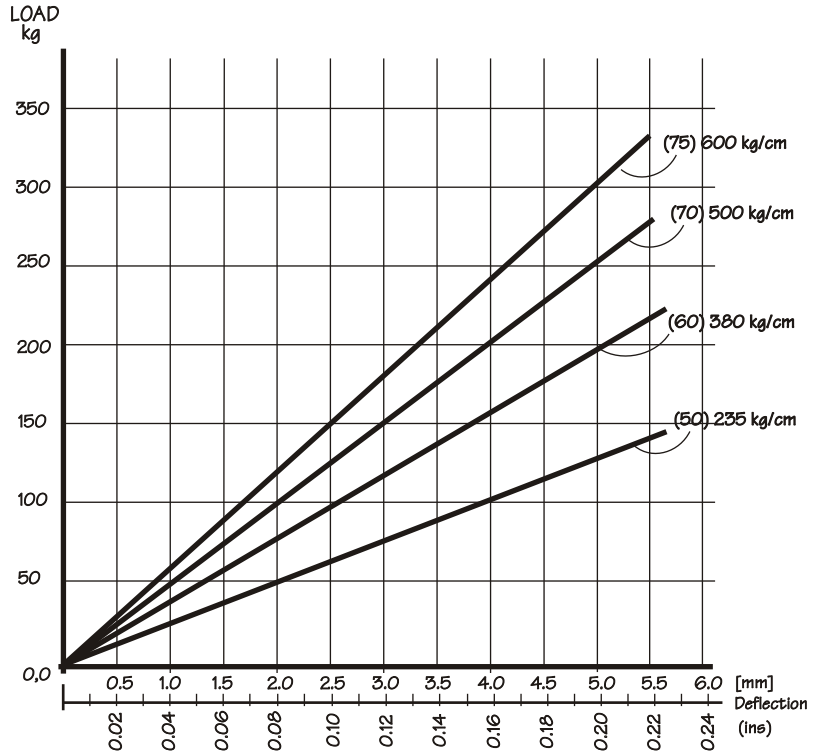

Graph 1: Static Axial Vertical Load[kg] (A-direction) versus Deflection[mm] (in)
 Data shown: (x) = SDH-A Hardness
 kg/cm = Spring Rate

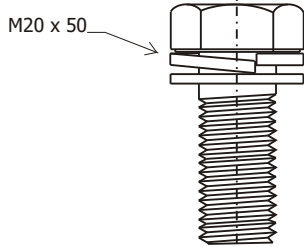

Note: the bolt length required is dependent on the application, a standard length bolt is supplied. Allow a minimum of 1x bolt dia & maximum of 1.5x bolt dia into the mount. 2x flat washers & 1x spring washer supplied, ensure that they are fitted as shown.

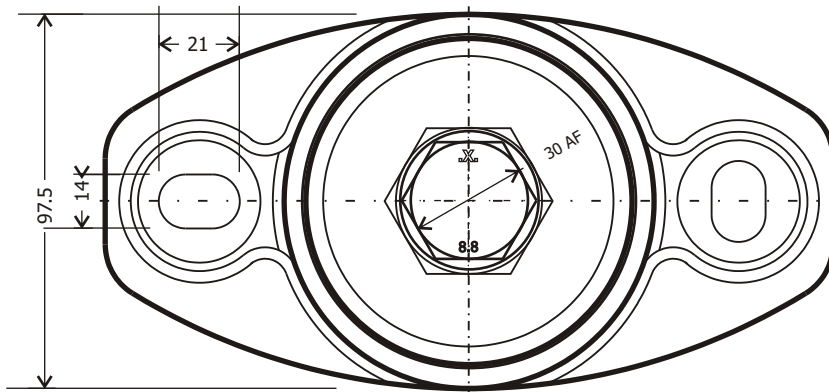
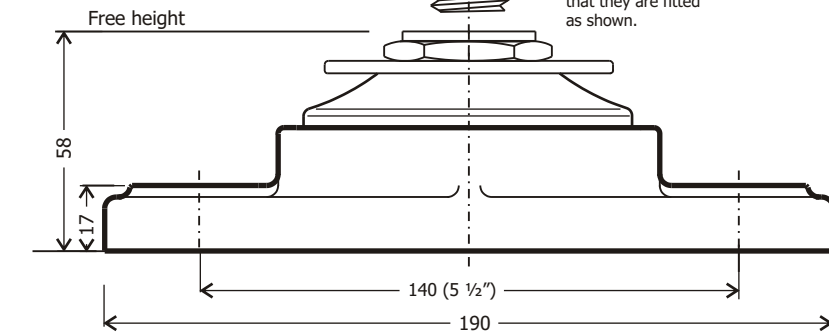

M80-20B-General Arrangement

Dimensions in millimetres (mm.) - unless stated otherwise



Model: M80-16B(60) shown

Drawing number: DSA-M80-20B
 Drawn: PB Date: 11-10-06