



# IsoFlex Technologies Pty Ltd.

Unit 5, 7 Waterway Drive, Gold Coast Marine Precinct, Coomera, Queensland, Australia. 4209  
 Ph: 1300 366 393 Ph: 07 555 60 924 F: 07 555 60 984 Int prefix: 617  
 Email: info@isoflex.com.au  
 Home Page: www.isoflex.com.au

## IsoFlex Mount Data Sheet

### Loadings:

1. Axial - Vertical Down (A-direction)

### Mount Model: M80-16B

'M80' = model number  
 '16' = thread size  
 'B' = bolt type

Resilient Element Colour	Shore Durometer Hardness A-scale SDH-A
Yellow	50
Red	60
Black	70
Royal Blue	75

Base: Black - 75 SDH-D

All metal components silver zinc plated

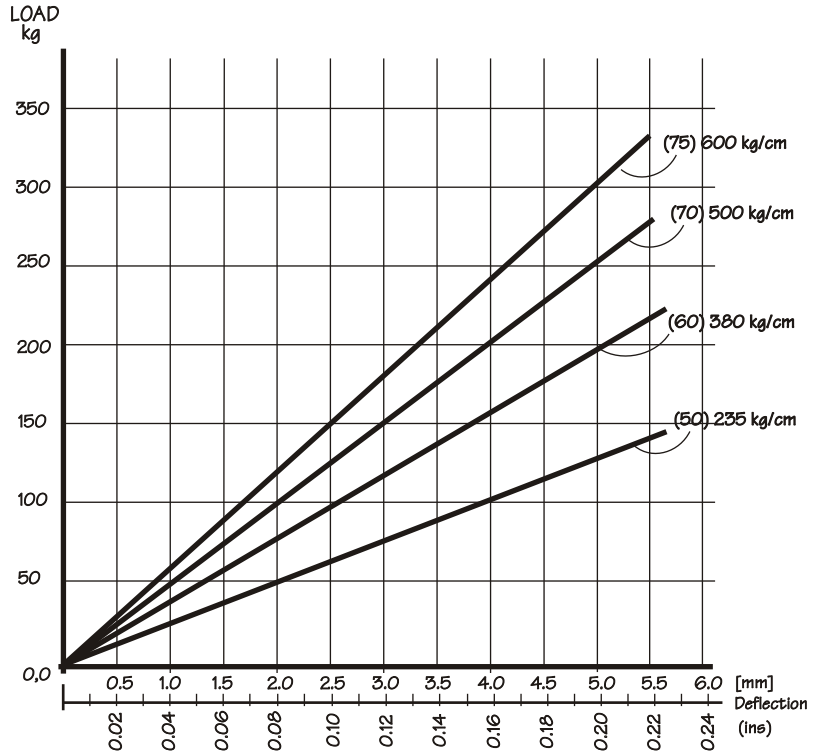

Graph 1: Static Axial Vertical Load[kg] (A-direction) versus Deflection[mm] (in)

Data shown: (x) = SDH-A Hardness  
 kg/cm = Spring Rate

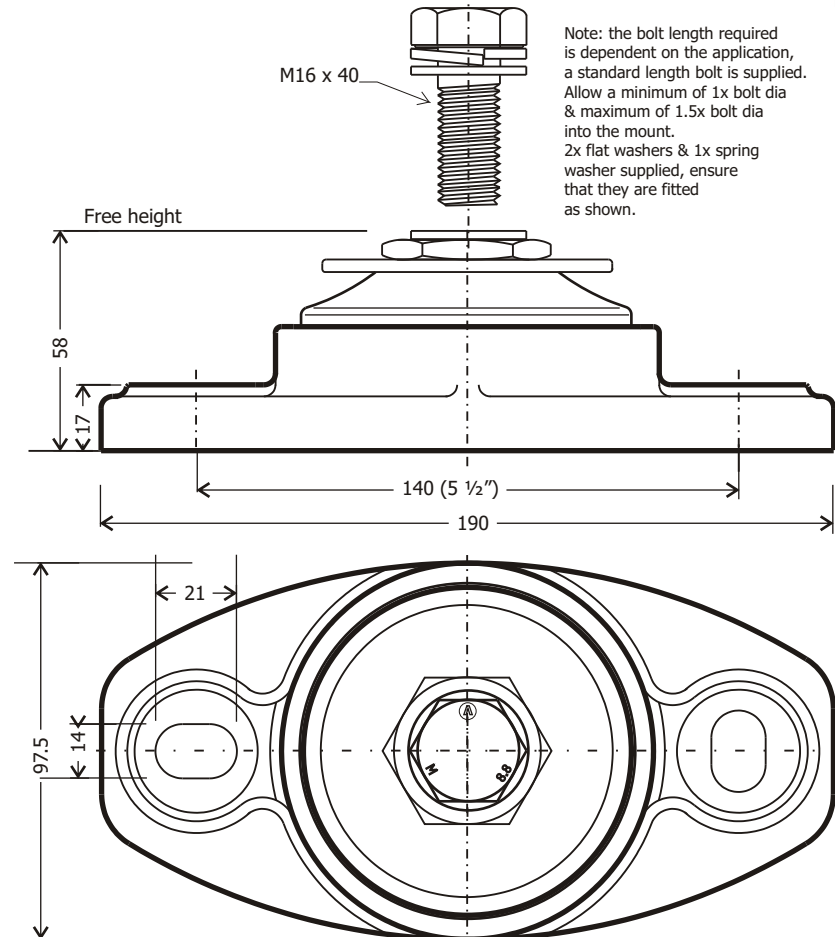

M80-16B-General Arrangement

Dimensions in millimetres (mm.) - unless stated otherwise



Model: M80-16B(60) shown

Drawing number: DSA-M80-16B  
 Drawn: PB Date: 11-10-06