



IsoFlex Technologies Pty Ltd.

Unit 5, 7 Waterway Drive, Gold Coast Marine Precinct, Coomera, Queensland, Australia. 4209
 Ph: 1300 366 393 Ph: 07 555 60 924 F: 07 555 60 984 Int prefix: 617
 Email: info@isoflex.com.au
 Home Page: www.isoflex.com.au

IsoFlex Mount Data Sheet

Loading:

1. Axial - Vertical Down (A-direction)

Mount Model: M50-12S

'M50' = model number
 '12' = thread size
 'S' = adjusting stud type

Resilient Element Colour	Shore Durometer Hardness A-scale SDH-A
Yellow	50
Red	60
Black	70

Base: Black - 75 SDH-D

All metal components silver zinc plated

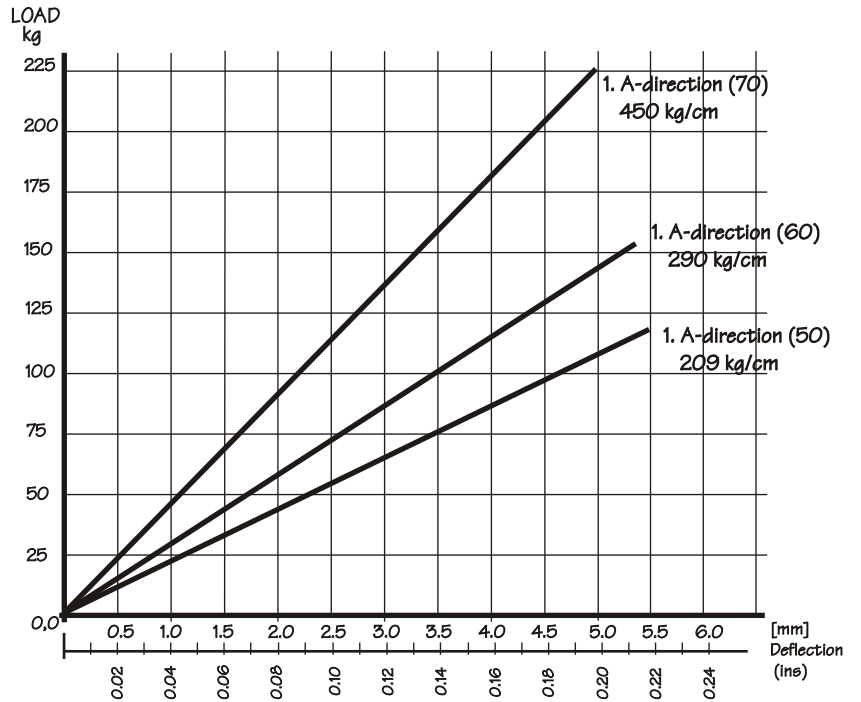

Graph:
 1. Static Axial Vertical Load[kg] (A-direction) versus Deflection[mm] (ins)

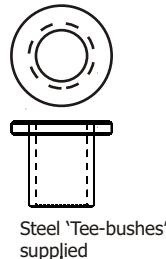
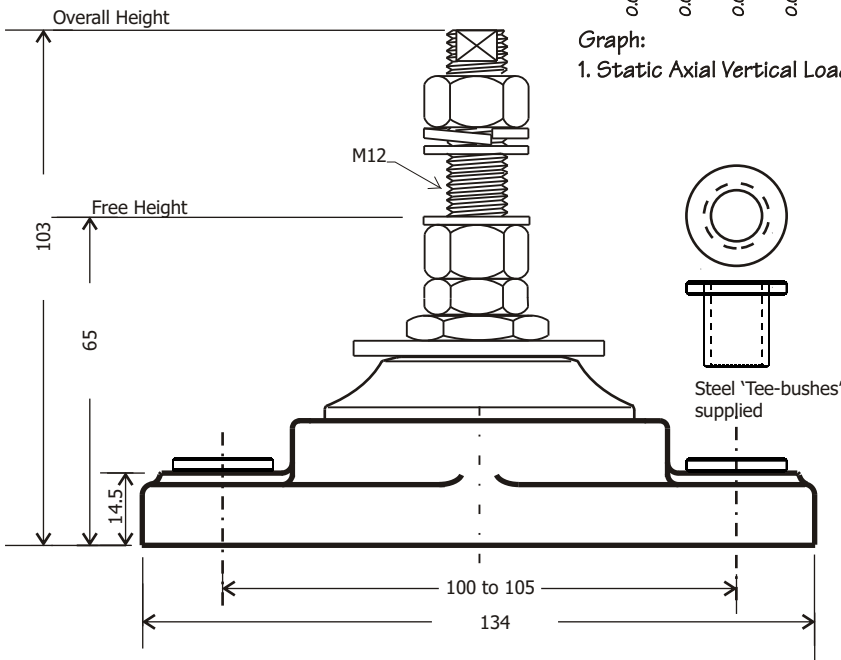

Model Number: M50-16S(50) shown

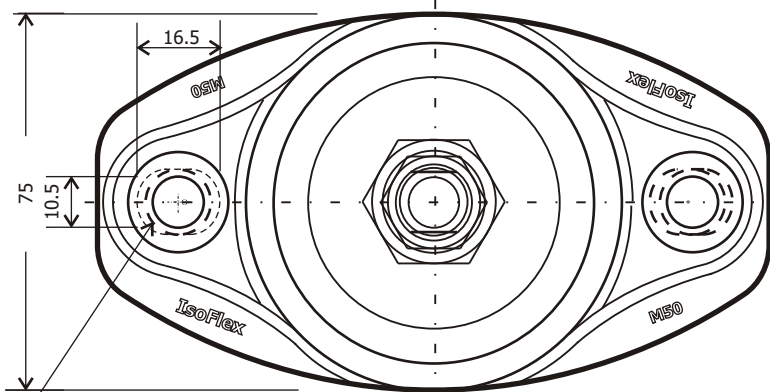

M10 / 3/8" (9.6mm)
 Tightening torque = 15 N-m (11 ft-lbs)

M50-12 General Arrangement

Dimensions in millimetres (mm.) - unless stated otherwise

Drawing number: DSA-M50-12S
 Drawn: PB Date: 25-8-06

Copyright © 2006 **IsoFlex Technologies Pty Ltd.**

Specifications are subject to change without notice.