



# IsoFlex Technologies Pty Ltd.

Unit 5, 7 Waterway Drive, Gold Coast Marine Precinct, Coomera, Queensland, Australia. 4209  
 Ph: 1300 366 393 Ph: 07 555 60 924 F: 07 555 60 984 Int prefix: 617  
 Email: info@isoflex.com.au  
 Home Page: www.isoflex.com.au

## IsoFlex Mount Data Sheet

### Loading:

1. Axial - Vertical Down (A-direction)

### Mount Model: M50-12B

'M50' = model number  
 '12' = thread size  
 'B' = bolt type

Resilient Element Colour	Shore Durometer Hardness A-scale SDH-A
Yellow	50
Red	60
Black	70

Base: Black - 75 SDH-D

All metal components silver zinc plated

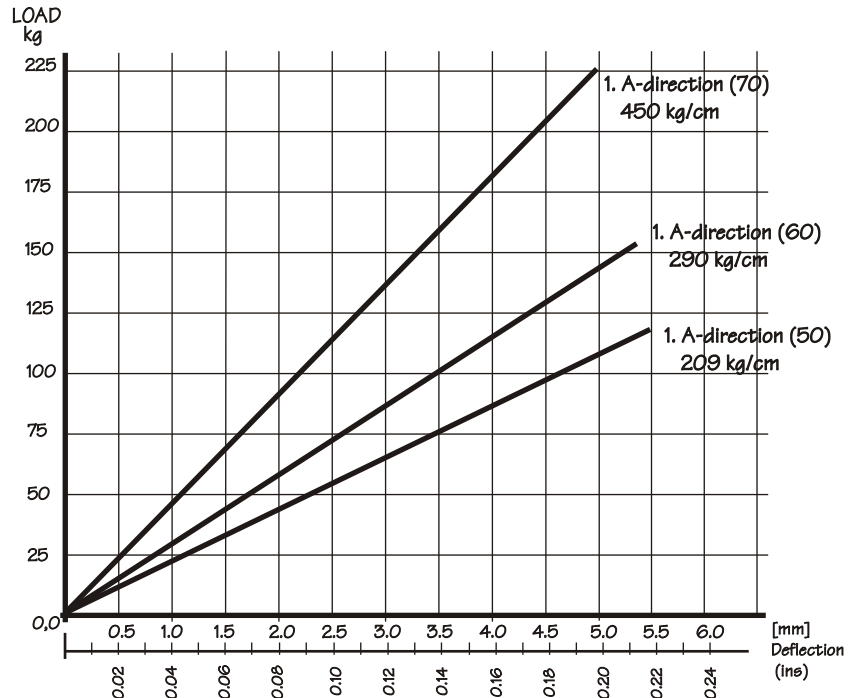

Graph:

1. Static Axial Vertical Load [kg] (A-direction) versus Deflection [mm] (ins)

Note: the bolt length required is dependent on the application, a standard length bolt is supplied. Allow a minimum of 1x bolt dia & maximum of 1.5x bolt dia into the mount. 2x flat washers & 1x spring washer supplied, ensure that they are fitted as shown.

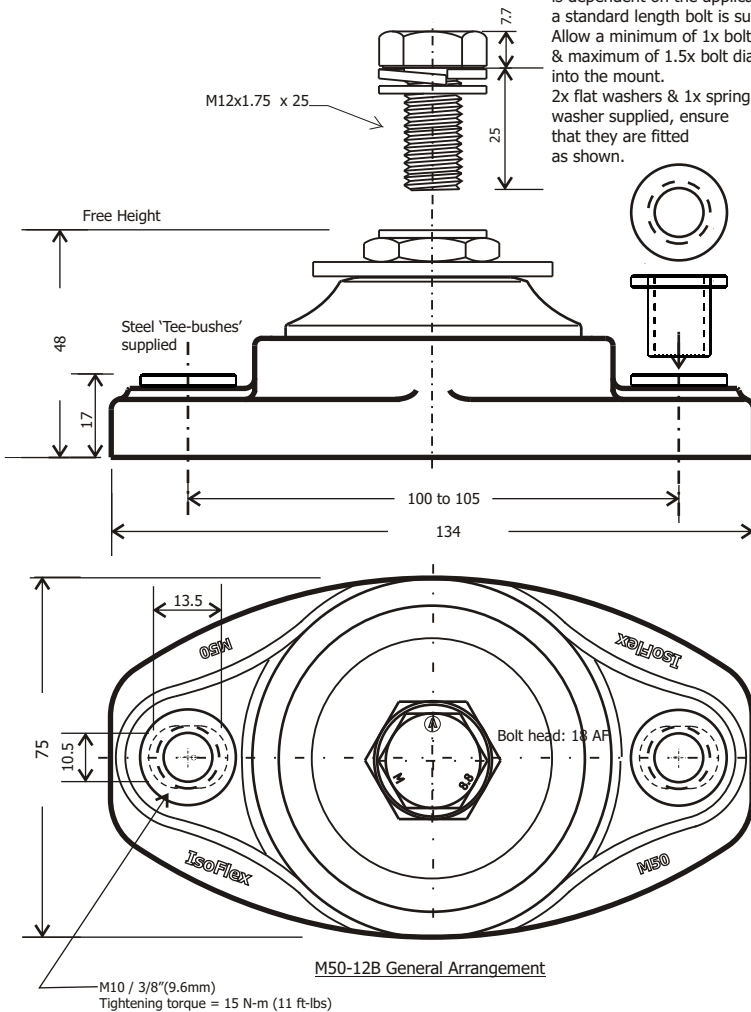

Model Number: M50-12B(60) shown

Drawing number: DSA-M50-12B  
 Drawn: PB Date: 14-9-06