



# IsoFlex Technologies Pty Ltd.

Unit 5, 7 Waterway Drive, Gold Coast Marine Precinct, Coomera, Queensland, Australia. 4209  
 Ph: 1300 366 393 Ph: 07 555 60 924 F: 07 555 60 984 Int prefix: 617  
 Email: info@isoflex.com.au  
 Home Page: www.isoflex.com.au

## IsoFlex Mount Data Sheet

### Loading Type:

**Axial - Vertical Down (A-direction)**

### Mount Model: M130HD-20B

'M130' = model number  
 '20' = thread size  
 'B' = bolt type

Resilient Element Colour	Shore Durometer Hardness A-scale SDH-A
Yellow	50
Red	60
Black	70
Royal Blue	75
Green	80
Grey	90

**Base:** Black - 75 SDH-D

All metal components silver zinc plated

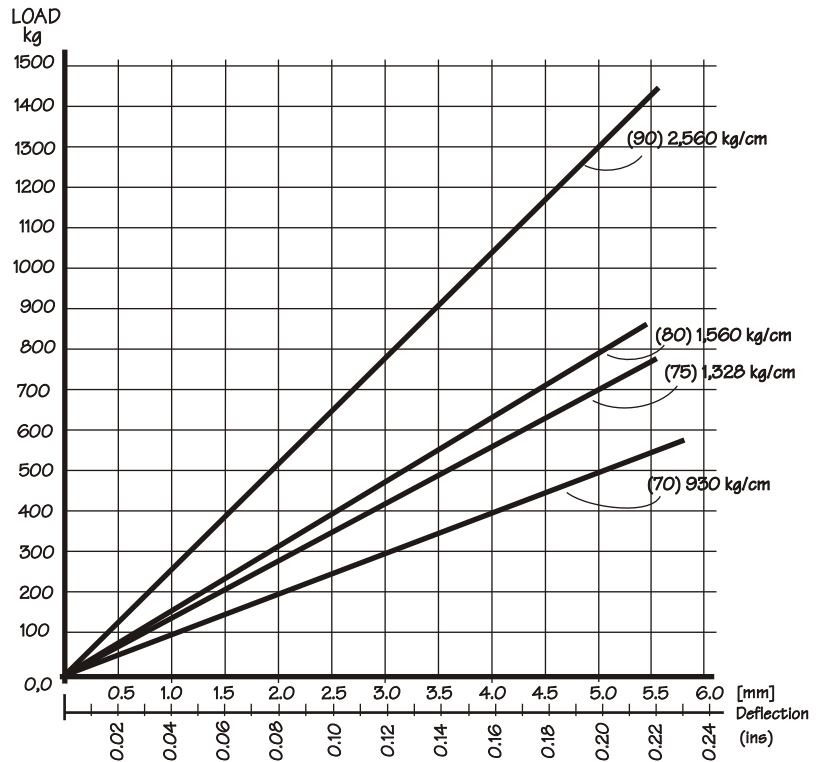

Graph 1: Static Axial Vertical Load [kg] (A-direction) versus Deflection [mm] (ins)

Data shown: (x) = SDH-A Hardness  
 kg/cm = Spring Rate

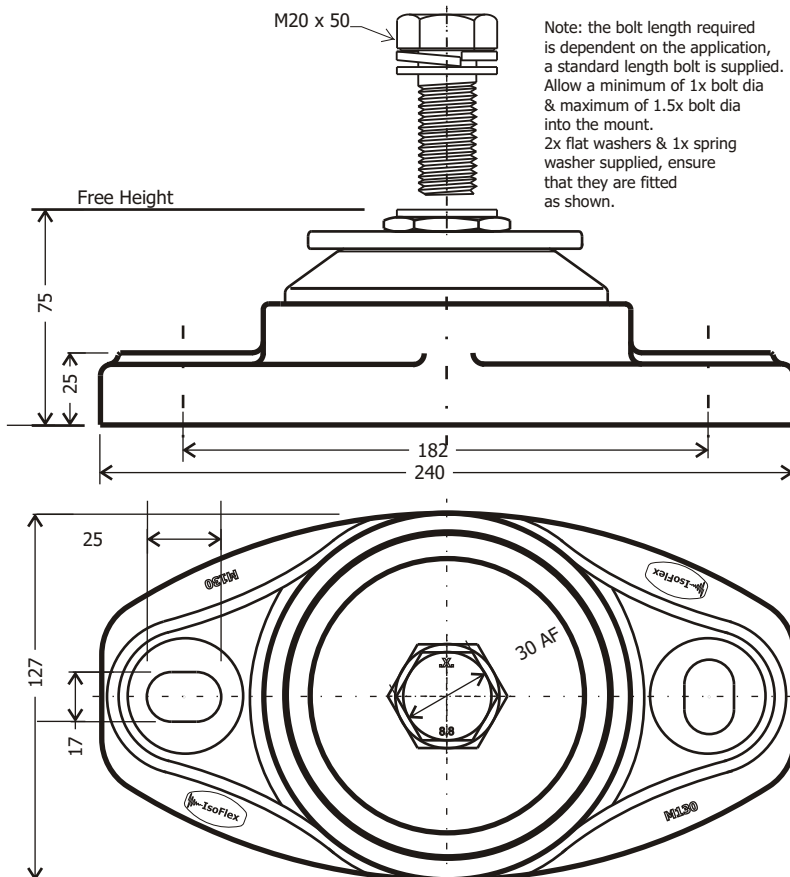

M130HD-20B General Arrangement

Note: the bolt length required is dependent on the application, a standard length bolt is supplied. Allow a minimum of 1x bolt dia & maximum of 1.5x bolt dia into the mount. 2x flat washers & 1x spring washer supplied, ensure that they are fitted as shown.



Model Number: M130-24B illustrated

Drawing number: DSA-M130HD-20B  
 Drawn: PB Date: 10-8-07