



IsoFlex Technologies Pty Ltd.

Unit 5, 7 Waterway Drive, Gold Coast Marine Precinct, Coomera, Queensland, Australia. 4209
 Ph: 1300 366 393 Ph: 07 555 60 924 F: 07 555 60 984 Int prefix: 617
 Email: info@isoflex.com.au
 Home Page: www.isoflex.com.au

IsoFlex Mount Data Sheet

Loading Type:

Axial - Vertical Down (A-direction)

Mount Model: M100-24B

'M100' = model number
 '24' = thread size
 'B' = bolt type

Resilient Element Colour	Shore Durometer Hardness A-scale SDH-A
Yellow	50
Red	60
Black	70
Royal Blue	75
Green	80
Grey	90

Base: Black - 75 SDH-D

All metal components silver zinc plated

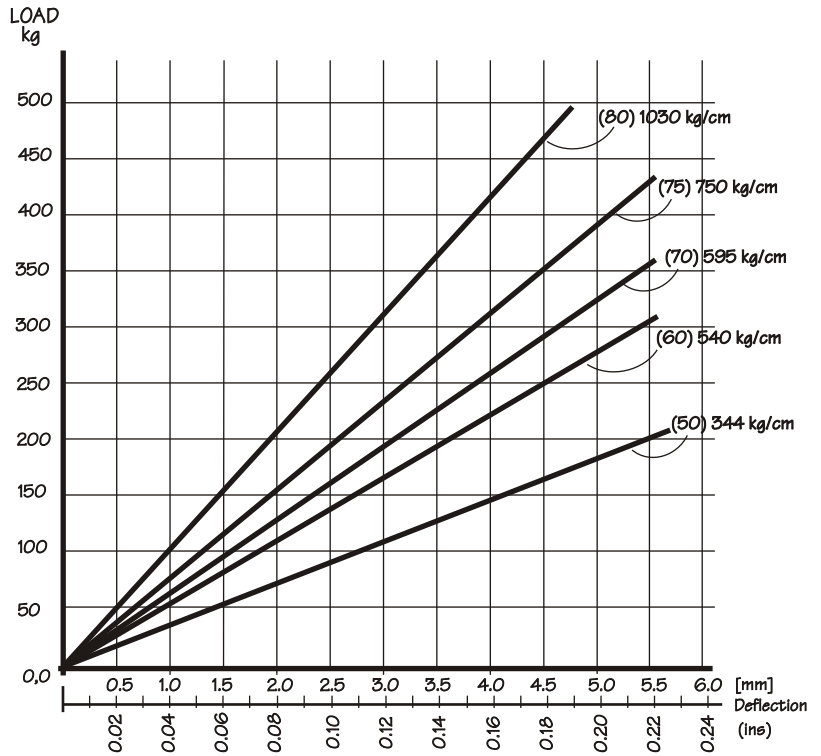

Graph 1: Static Axial Vertical Load [kg] (A-direction) versus Deflection [mm] (in)
 Data shown: (x) = SDH-A Hardness
 kg/cm = Spring Rate

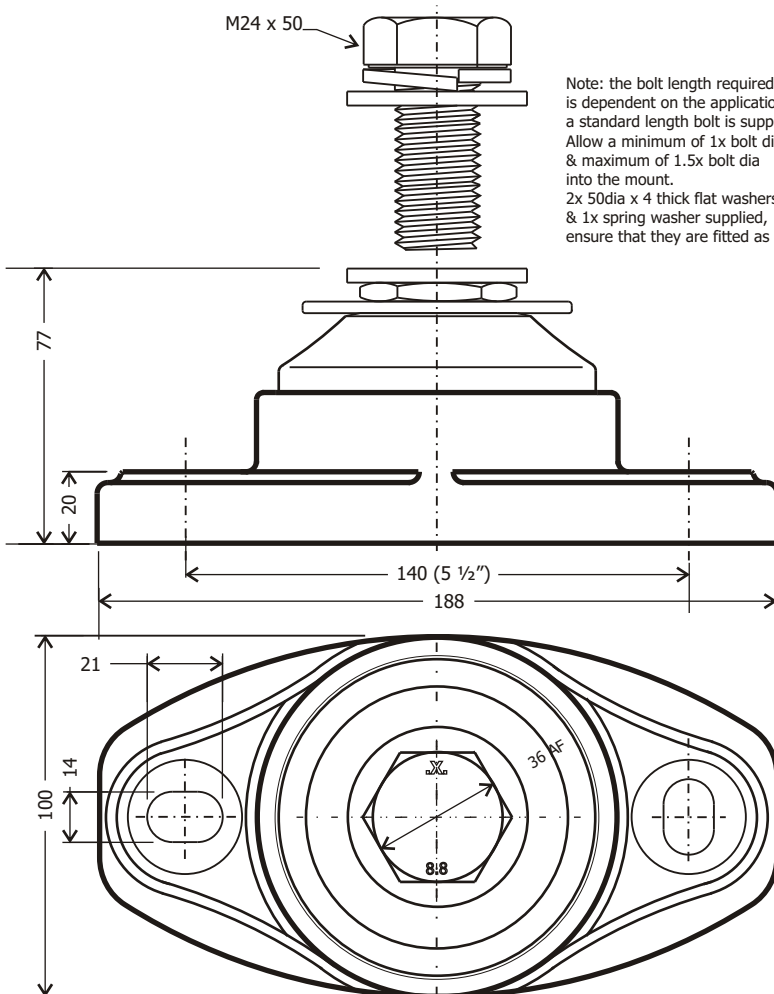

M100-24B General Arrangement

Dimensions in millimetres (mm.) - unless stated otherwise

Note: the bolt length required is dependent on the application, a standard length bolt is supplied. Allow a minimum of 1x bolt dia & maximum of 1.5x bolt dia into the mount. 2x 50dia x 4 thick flat washers & 1x spring washer supplied, ensure that they are fitted as shown.



Model Number: M100-24B illustrated

Drawing number: DSA-M100-24B
 Drawn: PB Date: 11-10-06